

# Omnio P/L

Assembly and operating instructions  
USA & CANADA

**visplay**

play it smart

This manual facilitates the safe and effective use of the “Omnio P/L” product.

This manual is a component of the product and must be kept on hand in the vicinity of the product at all times.

All personnel who deal with the product must have read this manual. Compliance with all the safety instructions and handling instructions specified in this manual is a prerequisite for safe work.

The illustrations in this manual are provided for the purposes of general understanding and may deviate from the actual version.

All dimension information in this manual is specified in **millimeters** and inches.

### Quality assurance

All processes in our company are subject to a comprehensive management system, which conforms to the quality standard ISO 9001 and the environmental standard ISO 14001.

The Zertifizierungs- und Umweltgutachter GmbH (BSI) company audits this management system regularly and documents compliance with the standard via a certificate.

### Copyright

This manual is protected by copyright. Its use is permissible as part of the use of the product. Any use other than this is not permitted without the written consent of the manufacturer.

Our General Terms and Conditions apply for all orders.

Omnio P/L is approved by the Underwriter Laboratories Inc.



## Content

<b>1 Safety .....</b>	<b>3</b>
1.1 Explanation of symbols .....	3
1.2 Intended use .....	3
1.3 Basic dangers .....	3
<b>2 Product description .....</b>	<b>4</b>
<b>3 Technical data .....</b>	<b>4</b>
3.1 Connected electrical loads .....	4
3.2 Mechanical weight loads .....	4
<b>4 General assembly and installation information .....</b>	<b>5</b>
4.1 Components .....	5
4.2 Construction principle .....	6
4.3 Electrical connection .....	6
4.4 Stability .....	8
<b>5 Assembly .....</b>	<b>9</b>
5.1 Unpacking .....	9
5.2 Storage .....	9
5.3 Requirements for the installation location .....	9
5.4 Components and tools (illustration) .....	9
5.5 Assembling the structure .....	10
5.6 Alignment .....	11
5.7 Wall fixing bracket .....	11
5.8 Use of shelf with a cut-out .....	12
5.9 Mounting the converter and cable tray .....	13
5.10 Metal covers .....	13
5.11 Wooden cover assembly .....	14
5.12 Large drawer assembly .....	15
5.13 Platforms .....	17
5.14 Installing the hanging rails .....	17
<b>6 Dismantling / modification .....</b>	<b>18</b>
<b>7 Operation .....</b>	<b>19</b>
7.1 Cleaning .....	19
<b>8 Disposal .....</b>	<b>19</b>
<b>9 Fault correction .....</b>	<b>19</b>

# 1 Safety

Read this manual before using the product for the first time and proceed accordingly. Keep this manual in a safe place for later use or to pass on to future owners.

## 1.1 Explanation of symbols

Warning notices are indicated in this manual as follows.

**⚠ WARNING**

A warning notice designated in this manner indicates a dangerous situation that could result in death or serious injury if it is not avoided.

**NOTE**

A warning notice designated in this manner indicates a potentially dangerous situation that could result in material damage or environmental damage if it is not avoided.

## 1.2 Intended use

The product is designed exclusively to hold merchandise supports for displaying goods.

Only merchandise supports and consumers that comply with the specifications list are approved.

**In the event of misuse, there is the danger that the merchandise supports and the electrical devices will be damaged. This can result in injuries and damage to the product.**

### Area of implementation

The product may only be used in the commercial area.

### Personnel

This manual describes how to install the product and how to operate and clean the product. Consequently after the product is installed this manual must be transferred to the end user.

The contents of the section on "Assembly" is directed at personnel, who undertake the assembly and the electrical connection (e.g. shop fitters, licensed electricians).

The contents of the section on "Handling" is directed at the end users (e.g. sales personnel, visual merchandisers).

## 1.3 Basic dangers

- > Use only approved accessories and electrical devices.
- > Comply with the permitted connection, maximum load and equipment values.
- > Do not lean any ladders against the merchandise supports.
- > Do not load the merchandise supports above the maximum load capacity.
- > Do not place any receptacles, from which fluids can escape, on the merchandise supports.
- > Keep moisture away from current conducting components.

- > Assemble or dismantle only when power plug is pulled out:

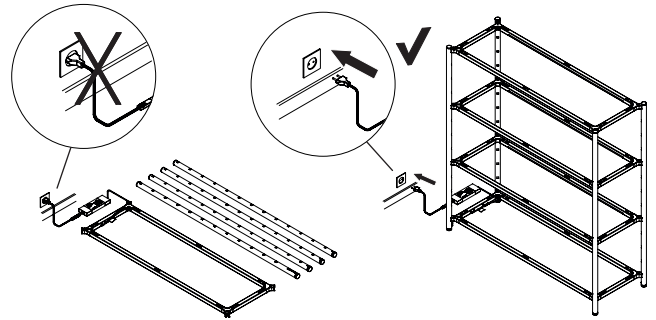

- > Lay the cable so that this does not pose a trip hazard:

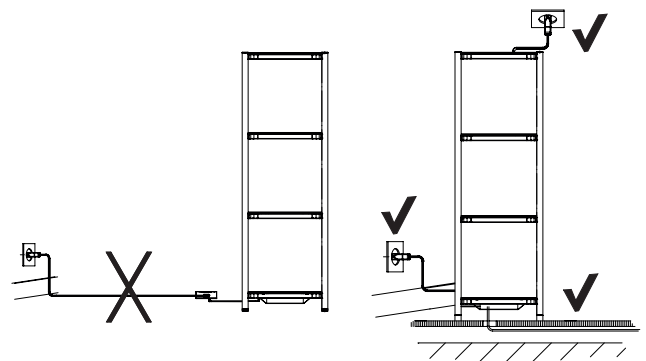

- > Align furniture / attached to the wall (1) and then fill (2). Observe section 4!

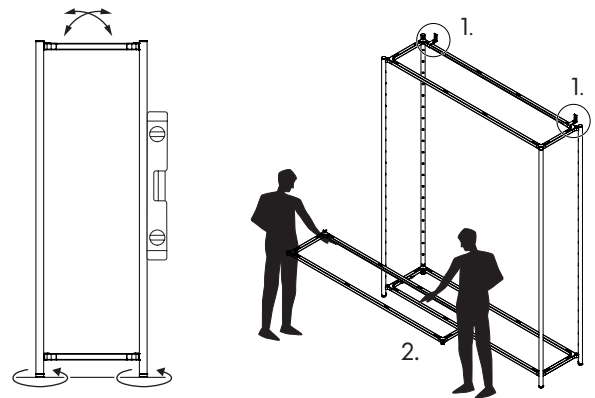

- > Even weight distribution Store heavy merchandise at the bottom. In the event of visible deformation, the prescribed load limit must not be exceeded! -> Reduce weight!

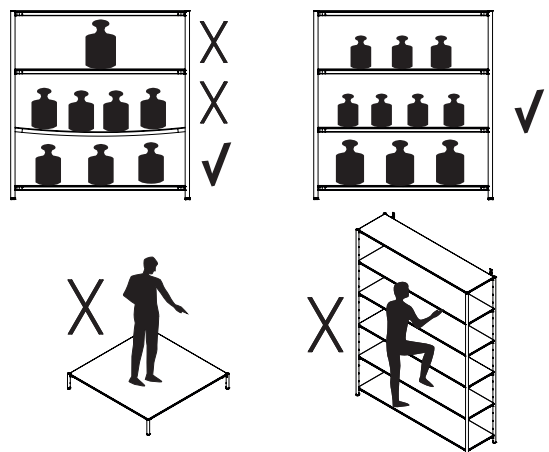

**EN 2 Product description**

Omnio P/L is an electrified structural system suited for space-defining purposes and interior design concepts. Being self-supporting when placed in central spaces as well as when located in front of walls, it offers a maximum level of freedom. The uprights and connection frames can be configured into customizable modules as required. These modules can be extended on all four sides. Due to the fact that it is easy to assembly, modify and dismantle, the system can be changed at short notice. The sophisticatedly integrated 24 V current feed makes the single- to four-sided connection of illuminated shelves, lights and digital devices possible. Thanks to its reserved design, Omnio can be ideally used as centre-floor furniture, as a space divider, but can also be used in front of walls.

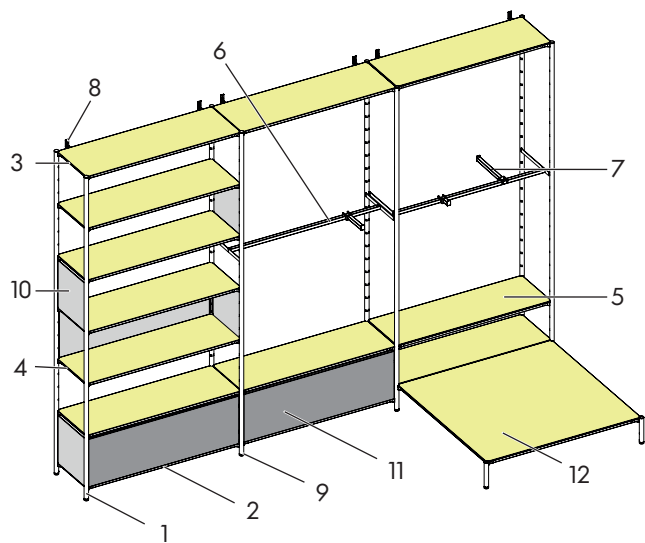

Fig. 1: Omnio P/L

1	Electrified / non-electrified uprights
2	Connection frame with feed cable
3	Connection frame with / without LED
4	Shelf frame with / without LED
5	Metal/glass/wooden shelf
6	Hanging rails
7	Merchandise supports
8	Wall bracket
9	Height-adjustable glide
10	Metal / wooden side panels
11	Metal / wooden drawers
12	Platform

**3 Technical data**

**3.1 Connected electrical loads**

The system can be supplied via one or two 24 V power supply units connected in parallel. All electrical furniture components are operated using safety extra low voltage (SELV). The maximum power specifications must absolutely be adhered to. For detailed planning and electrical connection information, see section 4.

Specification	Value	Unit
Connection / mains power	230/240	V AC
Frequency	50-60	Hz
Converter protection class	II	
System operating voltage	24	V DC
System components protection class	III	
Maximum power for each power-feed point	7 168	A W



**3.2 Mechanical weight loads**

The specified weight loads refer to the components listed in the Visplay manual. The maximum weight loads shall apply with respect to a uniform load distribution. In the event of visible warpage of the merchandise supports, the permissible weight load has been exceeded and the load must be reduced immediately.

Component	Value	Unit
Connection/shelf frame with support insert	<b>30</b>	kg
	66.138	lbs
Platforms	<b>30</b>	kg
	66.138	lbs
Drawers	<b>30</b>	kg
	66.138	lbs
Hanging rail	<b>52</b>	kg
	114.639	lbs
Merchandise support	<b>20</b>	kg
	44.092	lbs

## 4 General assembly and installation information

Omnio P/L offers a multitude of possibilities. Prior to use, it is necessary to become familiar with the individual components and their respective functions, as well as the limits of the system. The following symbols help to differentiate the components.

	Connection frame designation
	Upright designation slotted 1x, 2x, 3x, 4x, not electrified
	Upright designation slotted 1x, 2x, 3x, 4x, electrified

### 4.1 Components

#### Non-electrified upright

Non-electrified uprights are not fitted with a power track and are used solely for mechanical connection.

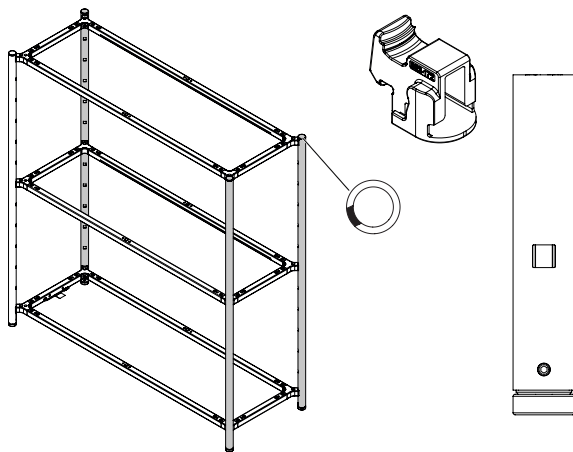

Fig. 2: Non-electrified uprights

#### Electrified upright

Electrified uprights are fitted with a power track. An electrified upright is always positioned on the front left of the furniture.

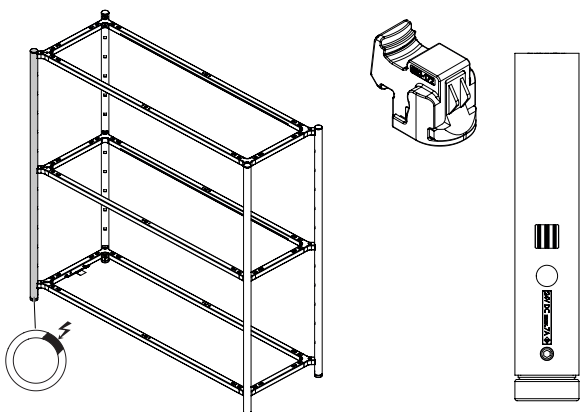

Fig. 3: Electrified upright

#### Connection frames

Two connection frames form a fixed shelf structure in conjunction with four uprights. The connection frame has a hexagonal screw (SW5) in each corner.

Electrified connection frames are fitted with a contacting unit on its underside under the front left corner (identified with yellow sticker).

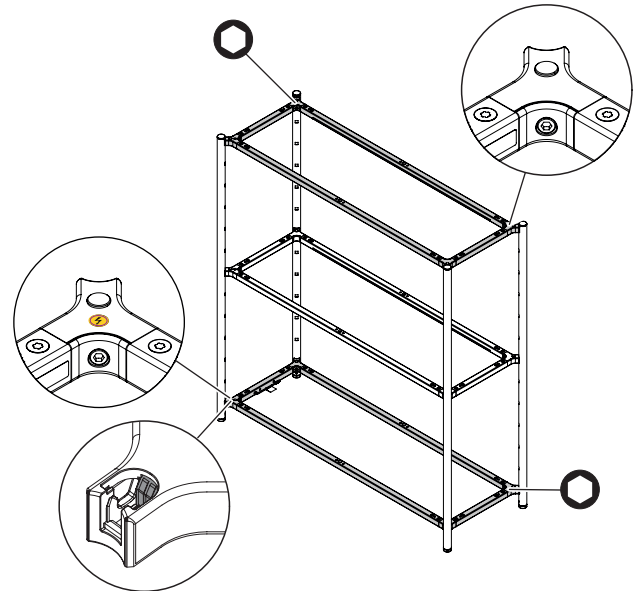

Fig. 4: Connection frames

#### Connection frame with feed cable

A connection frame with a feed cable is used for electrified structures. The frame is fitted with a cable and a connector. The connection frame is connected to a converter and feeds the current into an electrified upright.

Electrified connection frames are fitted with a contacting unit on its underside under the front left corner (identified with yellow sticker).

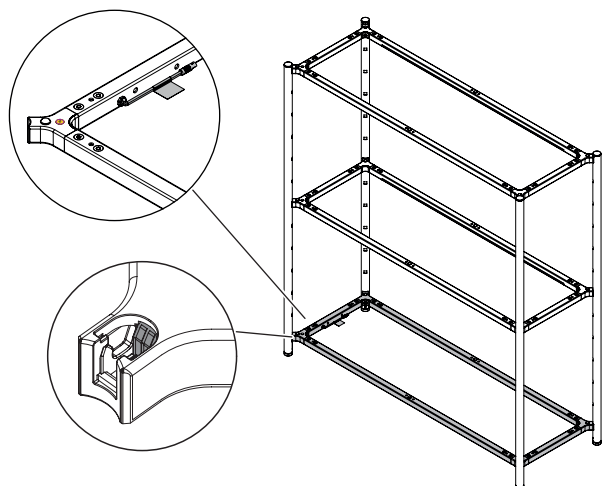

Fig. 5: Connection frame with feed cable

EN

## Shelf frame

The shelf frame is positioned on the inserted shelf supports. There are no screws in the corners of shelf frames. They are simply placed onto the shelf supports.

Electrified shelf frames are fitted with a contacting unit on its underside under the front left corner.

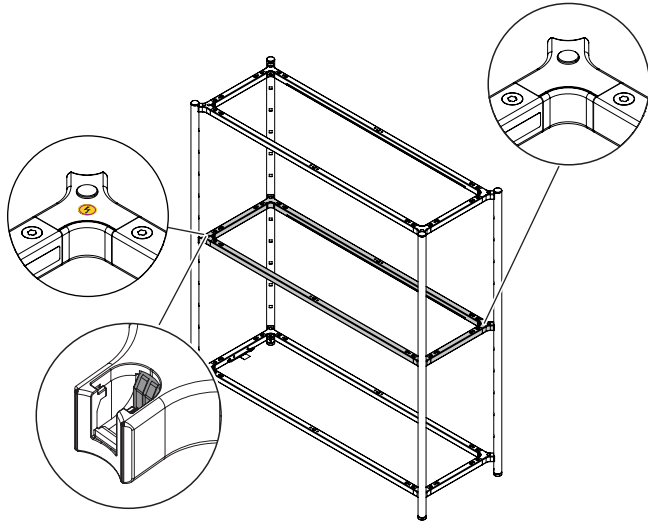

Fig. 6: Shelf frame

## 4.2 Construction principle

The electrified uprights are fitted on the front left of every item of furniture. On the corners of the furniture, single slotted uprights, between two axes, or in the case of corner structures two- or three-slotted uprights can be installed. With four-slotted upright, you can obtain the widest range of flexibility for modifications.

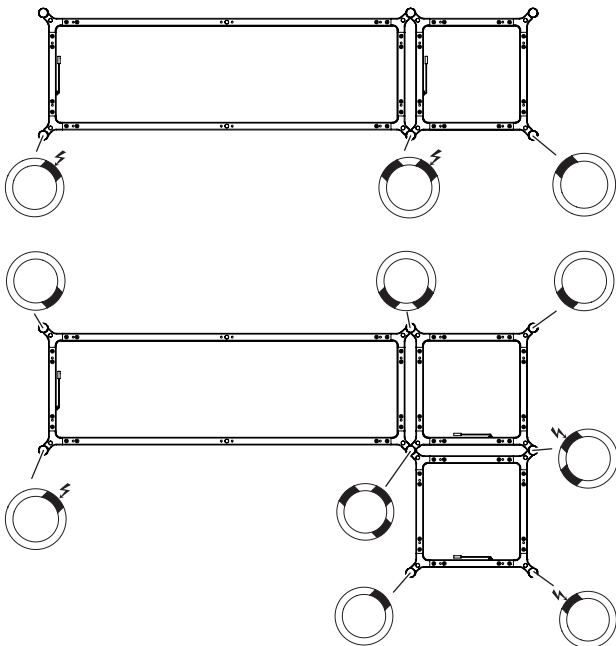

Fig. 7: Construction principle

## 4.3 Electrical connection

### NOTE

**The 24 V system is operated using one or two power supply units connected in parallel. It is permitted to connect a maximum of 168 W for each power-feed point. It is imperative to take account of power consumption of the electrical devices!**

For the sake of ensuring easy planning, assembly and operation, we recommend installing one or two power supply units for each axis according to the power requirements at hand. This makes assembly, modification, and, if required, troubleshooting easier.

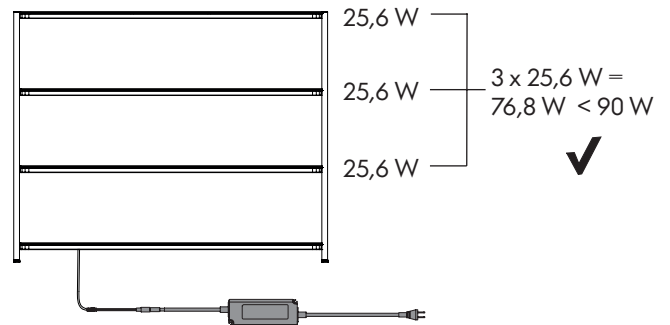

In the case of a power level of power per axis, a plurality of axes can also be supplied via distributor.

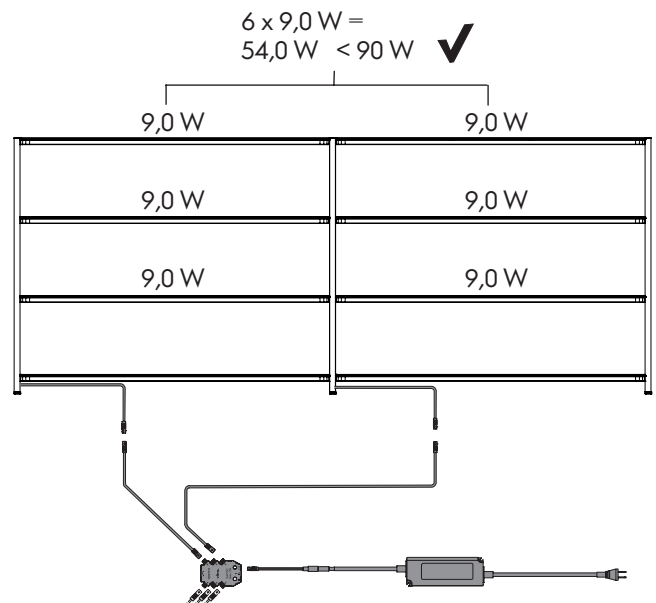

**90 W converter**

Converter dimensions, power-dependent

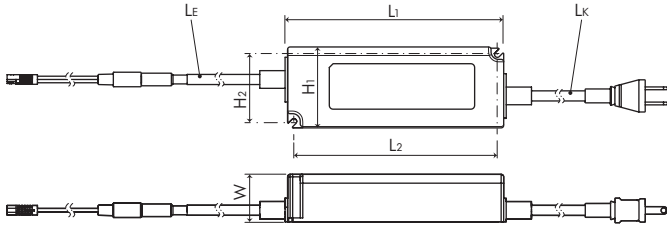

Fig. 8: Converter dimensions

Specification	90 W
Length [L1]	<b>171 mm</b> 6.732 inches
Length [L2]	<b>161 mm</b> 6.339 inches
Width [W]	<b>37.5 mm</b> 1.476 inches
Height [H1]	<b>63 mm</b> 2.480 inches
Height [H2]	<b>53 mm</b> 2.087 inches
Length - connecting cable to the infeed [LE]	<b>500 mm</b> 19.685 inches
Length - power cable [Lk]	<b>1500 mm</b> 59.055 inches

Component	Value
Operating voltage	120 V AC 60 Hz
Outlet tension	24 V DC max. 90 W
Ambient temperature	Max. 45 °C / 113 °F
Life cycle	MTBF 292,000 h
Max. number per circuit breaker	3x type B; 6x type C
Short-circuit, overload and thermal protection (automatic reset)	
UL certified	
Product safety UL8750	

**NOTE**

Before the furniture is connected to the electrical power, the following conditions must be met.

- > The furniture must be constructed according to the assembly instructions and be structurally stable. All consumers have been installed (merchandise supports, e.g. illuminated shelf frames).
- > The overall power of the consumers at a single power-feed point, does not exceed the maximum permissible power level of 90 W.
- > The overall power of the consumers does not exceed the power level of the connected converter.

**NOTE**

A maximum of four converters per power plug or HV extension cable permitted.

**24 V plug connection (secondary side)**

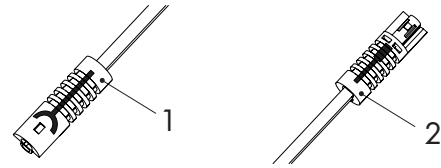

1	Coupling
2	Plug

**24 V DC distributor, 6-way**

For powering up to six profiles with a max. 90 W converter.

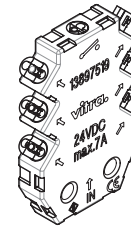

Fig. 9: Distributor, 6-way

**Extension cable 24 V DC**

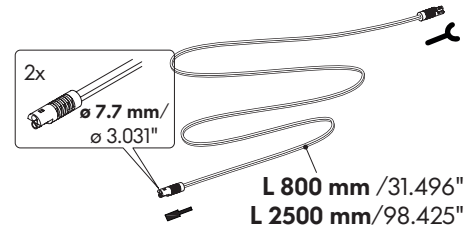

Fig. 10: Extension cable

**NOTE**

The cable length must be kept as short as possible and must not exceed 3000 mm/118.110". Connecting a plurality of extension cables in series is not permitted.

### 4.4 Stability

**⚠ WARNING**

Risk of injury due to tipping of the furniture and falling products.

- > Furniture with a lower-bearing capacity or a height of > 1700 mm/66.929" must be attached to the wall.
- > Stability is only ensured if located on firm level floors for furniture aligned in position and in the case of uniform weight distribution.
- > The maximum assembly heights and minimum load-bearing capacities must absolutely be adhered to.
- > The maximum heights shall always apply to the number of frames and support inserts shown!

The furniture widths show can be replaced by a plurality of smaller axes. For example, two **A600/23.622"** instead of one **A1200/47.244"**.

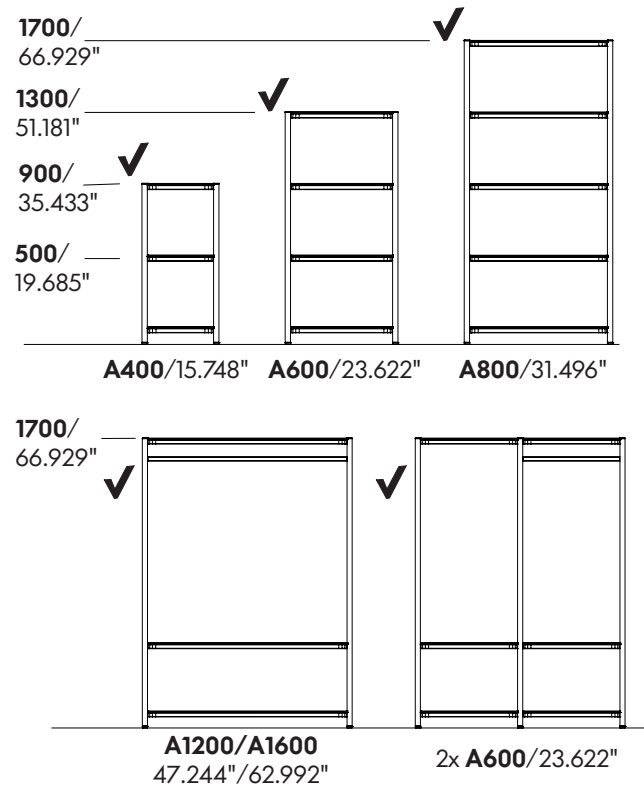

**⚠ WARNING**

Large drawers must only be used in the case of freestanding furniture with a minimum overall depth of 800 mm/31.496" (2x axis 400/15.748" back to back). Large drawers must only be installed on the bottommost level.

Maximum heights for structures with a 800 mm/31.496" depth and drawers:

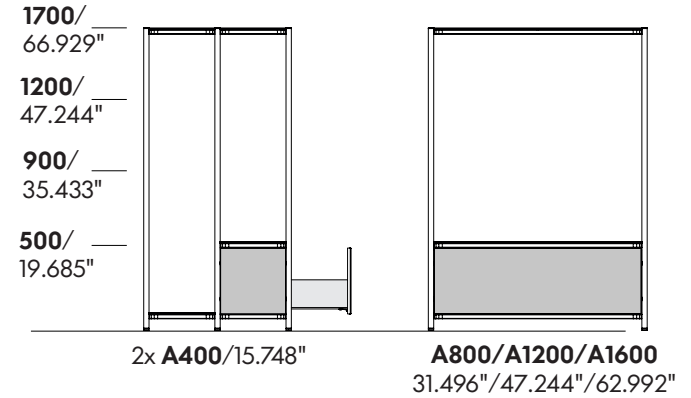

**NOTE**

The bottommost and topmost frame must always be a connection frame.

The following limits of the connection frame can be adjusted up or down. The maximum height and minimum weight load are required to ensure structural stability.

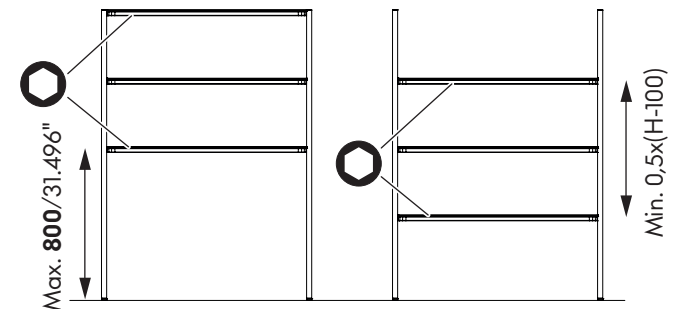
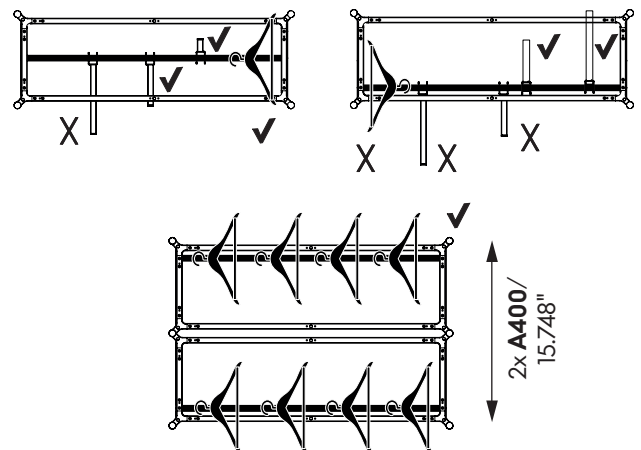

Fig. 11: Connection frame heights

The merchandise supports must not protrude beyond the outer edges of the furniture.





**⚠ WARNING**

**Furniture with a lower-bearing capacity or a height of > 1700 mm/66.929" must be attached to the wall.**

The follow applies to furniture attached to the wall:

- There is no minimum load-bearing capacity prescribed.
- The minimum distances of the connection frame must be adhered to.
- Large drawers up to a maximum height of **900 mm/35.433"** are permitted to be used.

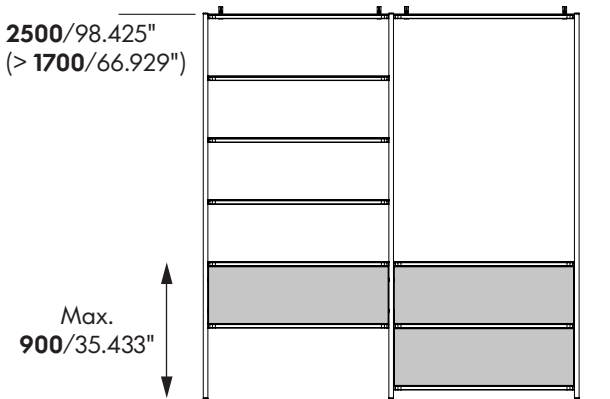

## 5 Assembly

**⚠ WARNING**

**Risk of injury from goods or merchandise supports falling down. If the installation is not executed properly or if the substrate cannot accommodate the necessary loads, the system can fail.**

- > **Note and comply with all the following instructions on assembly.**
- > **Make sure that the base is suitable for the expected loads.**

The structure shown must not correspond to the structure delivered to you; the general assembly logic is shown. For more information see section 4.

### 5.1 Unpacking

Check the delivery for completeness and transport damage immediately upon receipt.

Proceed as follows if there is apparent transport damage:

- Do not accept delivery, or only accept delivery subject to reservation.
- Note the scope of damage on the transport documents or on the delivery ticket of the freight forwarder.
- Initiate the claim process.

### Packaging

The product is safely packed so that transport damage is unlikely.

- Keep the original packaging for later transport.
- Only ship the product in the original packaging.
- Comply with all instructions that are specified on the packaging.

### Disposing of packaging material

If packaging material is no longer required, dispose of it in accordance with the locally-applicable disposal regulations.

### 5.2 Storage

Store the product and its components under the following conditions:

- Do not store outdoors.
- Store in a dry and dust-free location.
- Do not expose to aggressive media.
- Protect from sunlight.
- Avoid mechanical shocks.
- Storage temperature: 23 °C / 73.4 °F
- Relative humidity: 50 %

### 5.3 Requirements for the installation location

The installation location must meet the following requirements:

- The installation location must be dry. Installation outdoors is prohibited.
- The substrate (ground, walls, columns, etc.) must be configured for the loads that will be supported, and must be capable of accommodating these loads.

### 5.4 Components and tools (illustration)

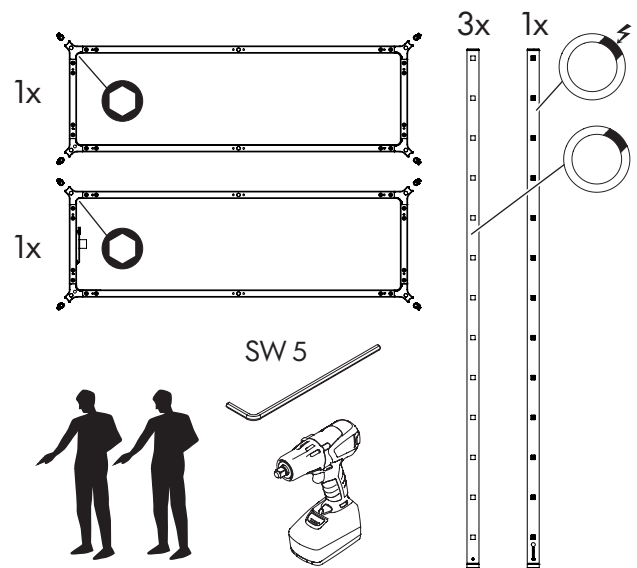

Fig. 12: Components and tools

	Connection frame designation
	Electrified upright designation
	Non-electrified upright designation

**EN 5.5 Assembling the structure**

**5.5.1 Fixing the first upright**

Installation of electrified structures starts with the electrified upright. Installation of non-electrified structures can start with any upright. The installation of an electrified upright is shown here by way of example.

1. Swivel the mount to insert it into the upright.

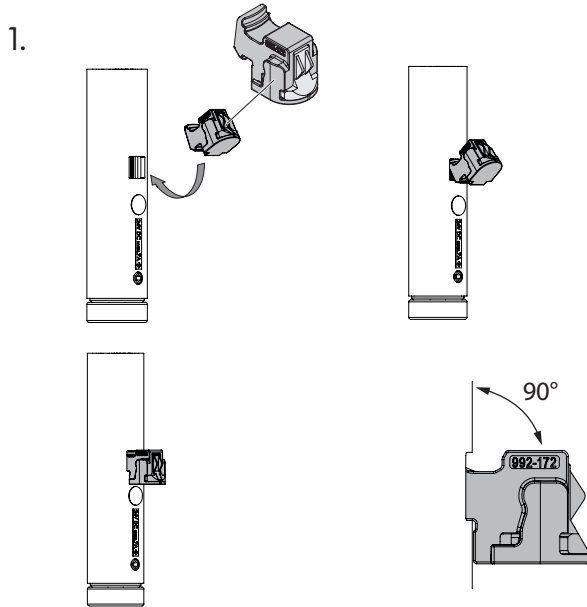

Fig. 13: Inserting the mount into the upright

Illustration of steps 2 - 5 on next page.

2. Make sure that all four screws on the connection frame are loosened.  
It is easier to press the frame down if the screw head is pressed in during installation.
3. Guide the electrified corner of the frame over the mount and press it downwards.
  - The mount must be flush with the bottom of the frame. This can be done by feel or by performing a visual inspection
4. Screw in all screws with a hexagon wrench or a cordless screwdriver with a hexagon bit (SW5).
5. Tighten all screws with a torque of 10 Nm.

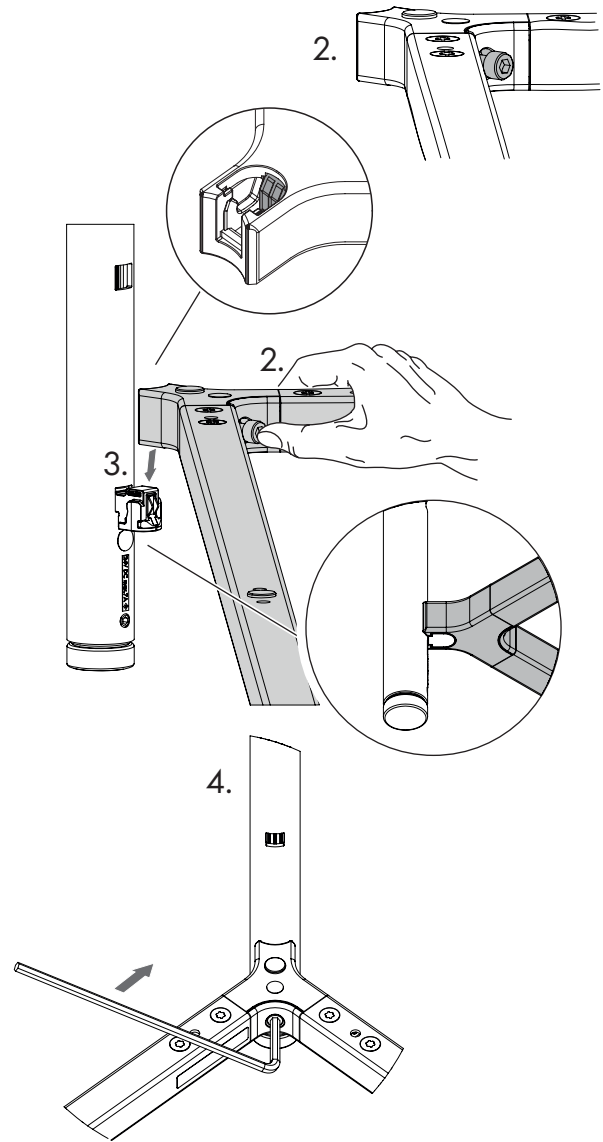

Fig. 14: Fixing the first upright

### 5.5.2 Fixing additional uprights

Hook the mounts into the uprights.

Insert the uprights onto the connection frame in sequence and screw them into place.

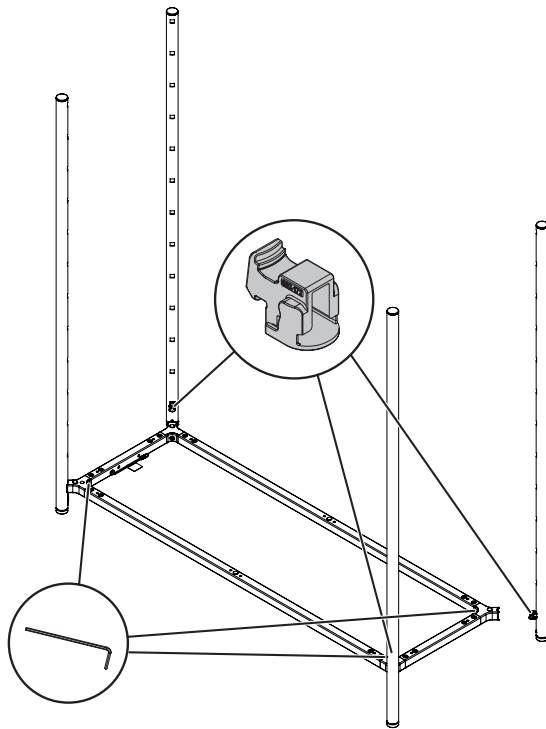

Fig. 15: Fixing additional uprights

### 5.5.3 Mounting the upper connection frame

Hook the mounts into the uprights, then fit the connection frame from above and screw it into place.

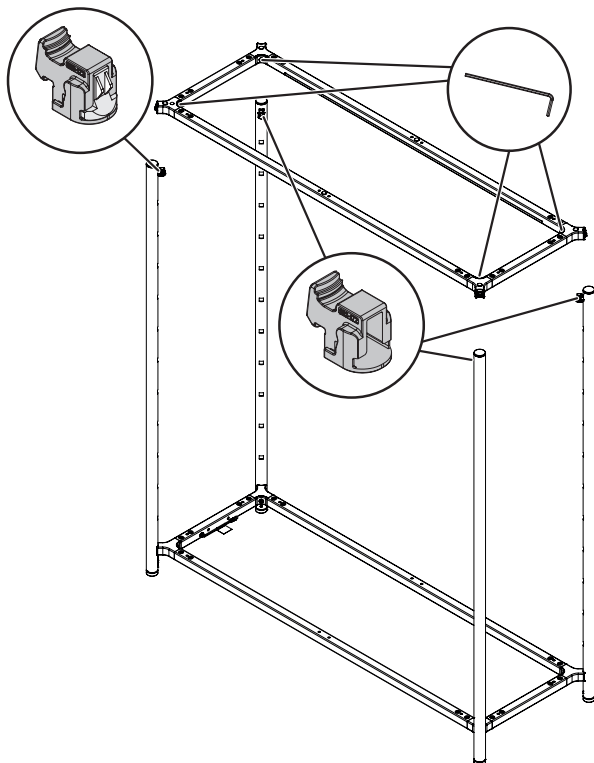

Fig. 16: Mounting the upper connection frame

### 5.6 Alignment

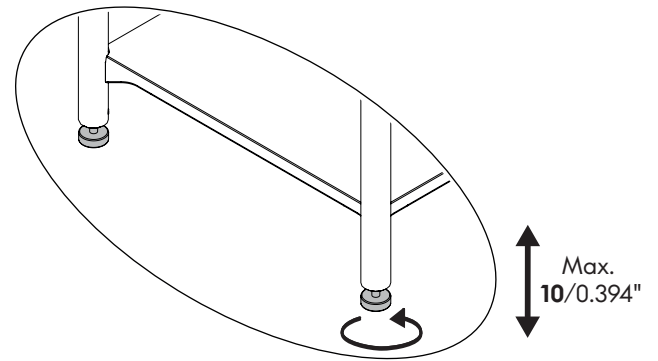

Fig. 17: Aligning the structure

### 5.7 Wall fixing bracket

**⚠ WARNING**

Risk of injury due to tipping of the furniture and falling products.

- > Furniture with a low load-bearing capacity or a height of > 1700 mm/66.929" must be attached to the wall.
- > Make sure that the fixtures and the base can support a pulling force of 0.1 kN per mounting point.

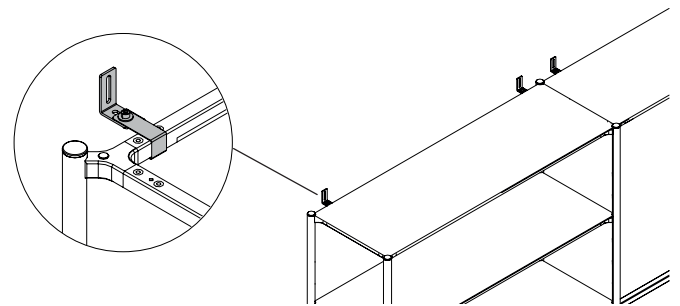
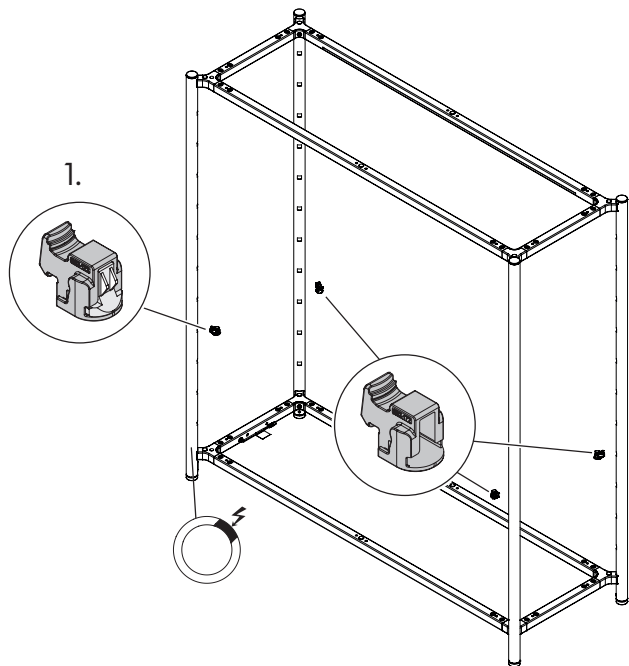

Fig. 18: Wall fixing bracket

EN

## 5.7.1 Mounting the shelf frame and inserting the shelf

1. Hook the shelf supports into the slot. Hook the electrified mount into the electrified upright (see marking). The electrification is on the front left.



2. Place the shelf frame on the shelf support.

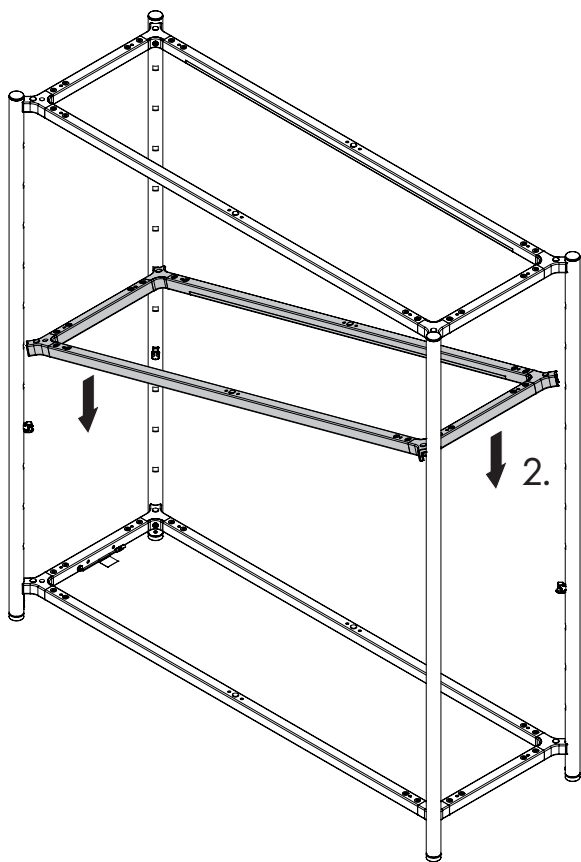

3. Hold the glass, metal and wooden shelves at a slight angle and slide them between the supports.
4. Place the supports on the shelf frame.

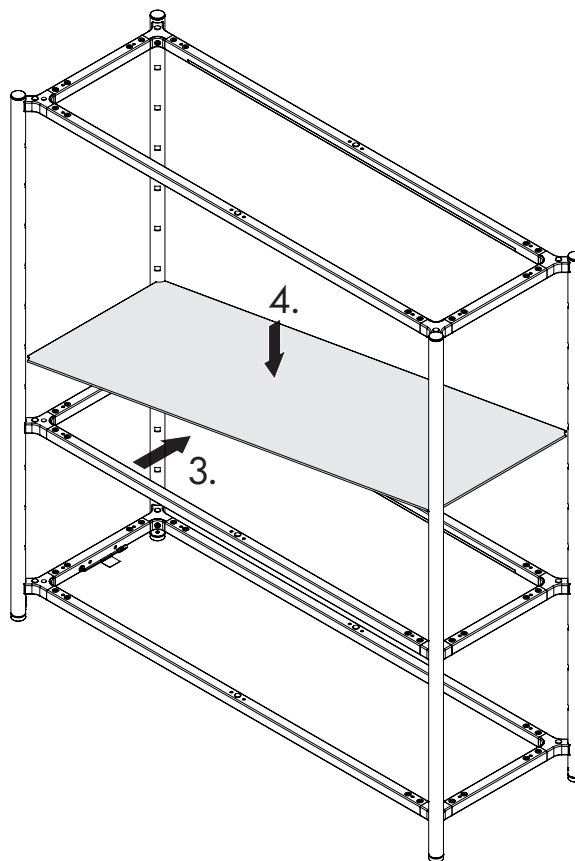

## 5.8 Use of shelf with a cut-out

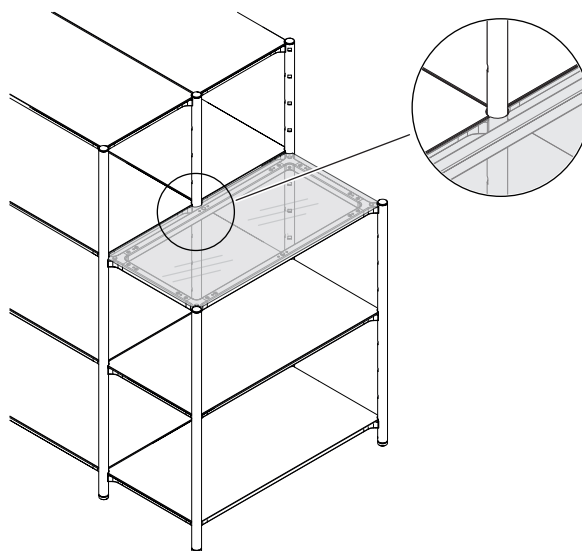

**5.9 Mounting the converter and cable tray**

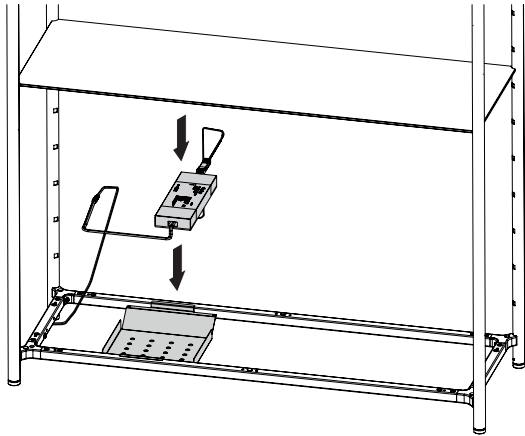

2. Move the lower folded edge behind the support insert.

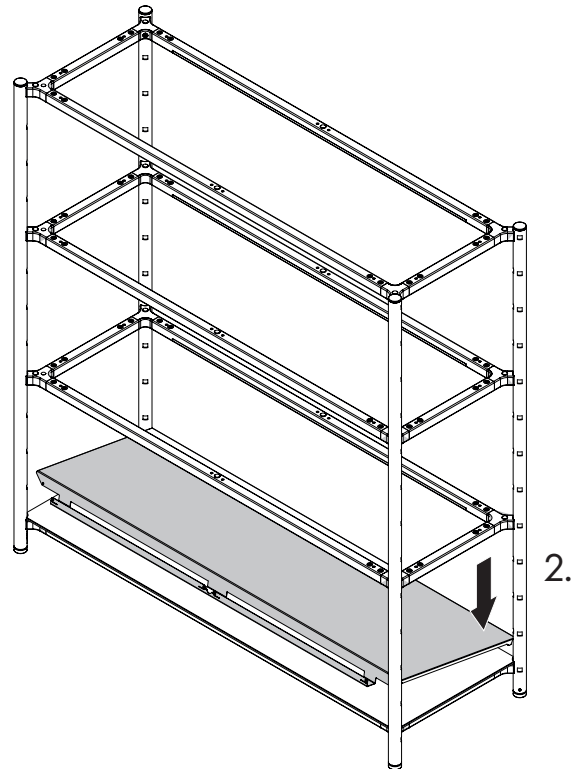

**5.10 Metal covers**

When fitting metal covers, work is systematically performed from bottom to top. All frames and the bottom-most support insert (metal/wood/glass) must be fitted.

1. Guide metal cover diagonally into the item of furniture

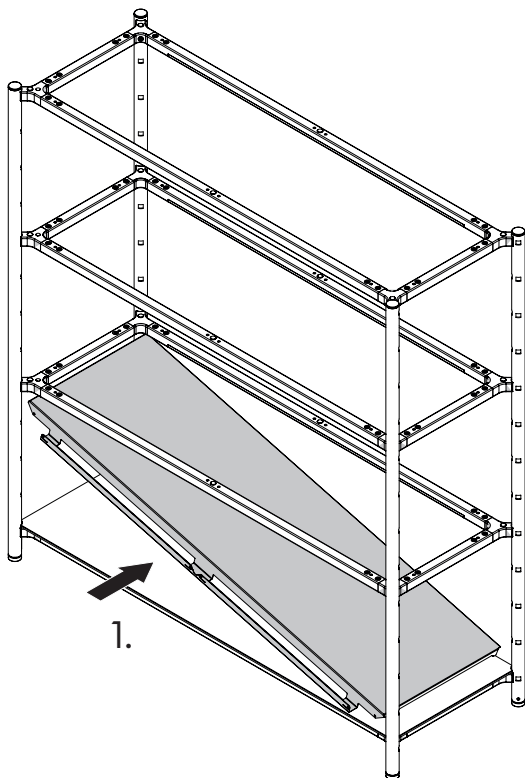

3. Swivel metal cover upwards so that this grips around the upper frame tube and engages into the holes.

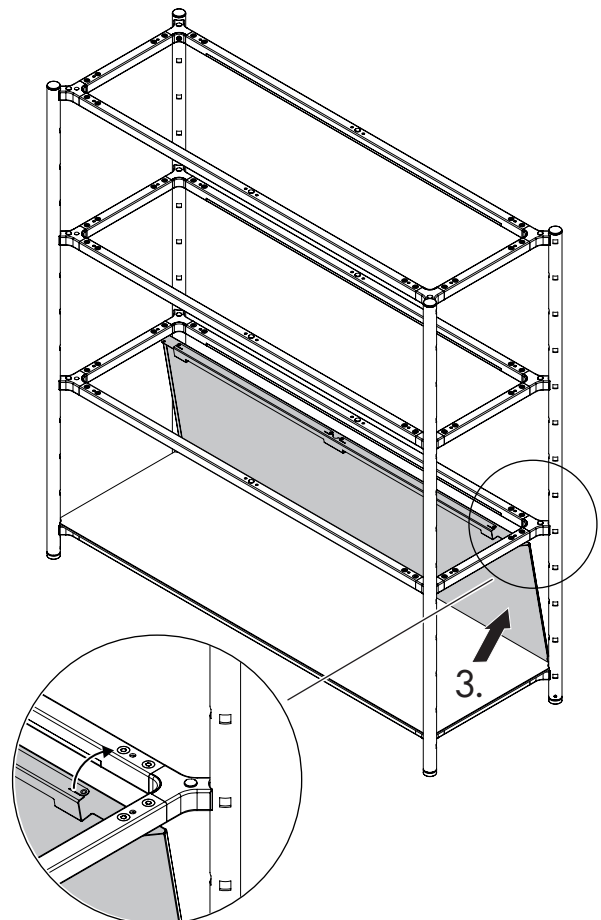

EN

4. Mount remaining covers.
5. Fit the next shelf.

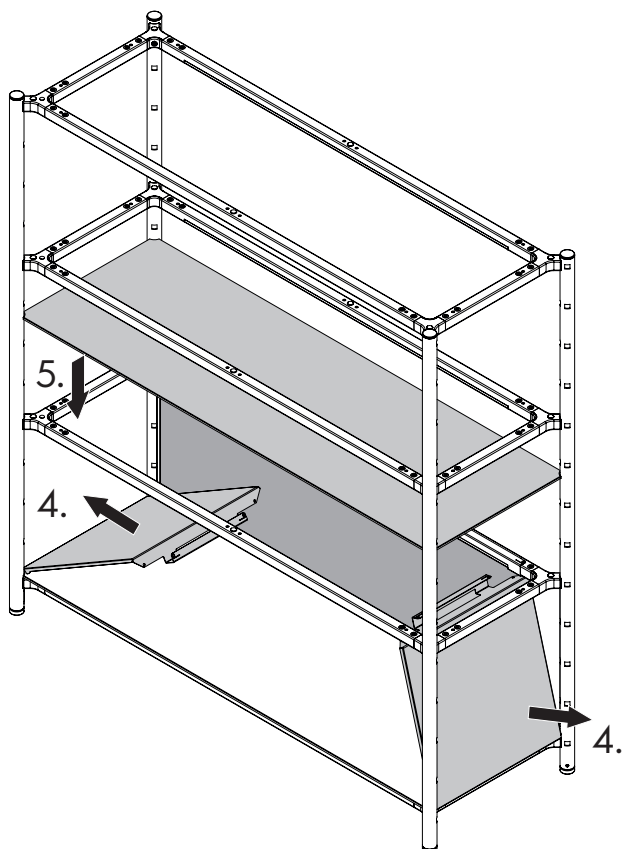

6. Two metal covers can be fitted back to back. In this way, for example, two adjacent niches can obtain a different surface.

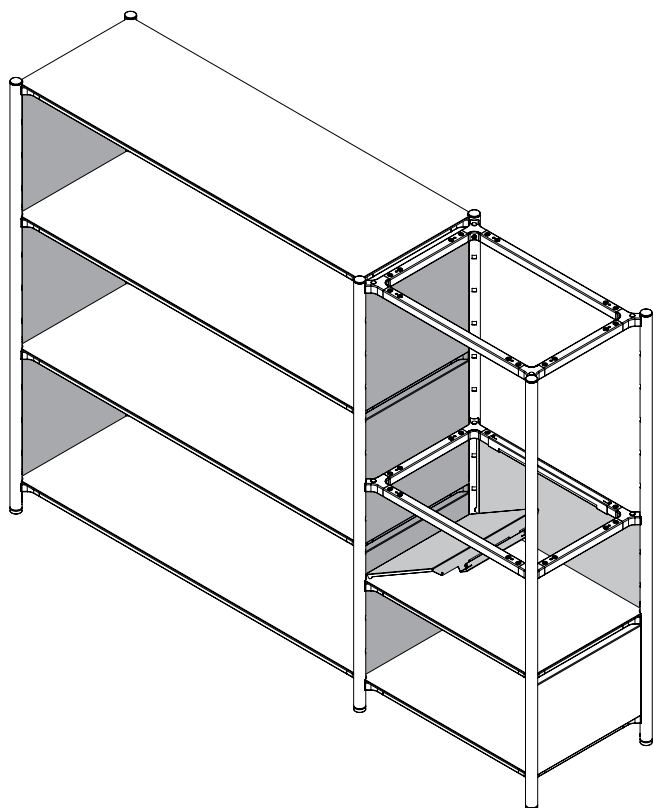

## 5.11 Wooden cover assembly

Wooden covers are set onto glass/wooden/metal support inserts. In the case of glass support inserts, the felt glides included within the scope of supply are glued onto the lower edge of the wooden cover.

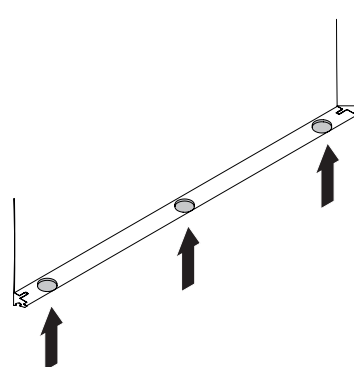

1. Insert the first side panel diagonally until it makes contact with the back upright.
2. Swivel in the front edge until it rests on the front upright.

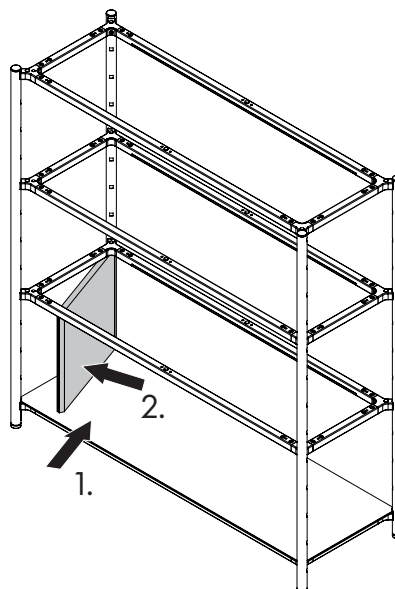

3. Repeat the steps with the other wooden panels.

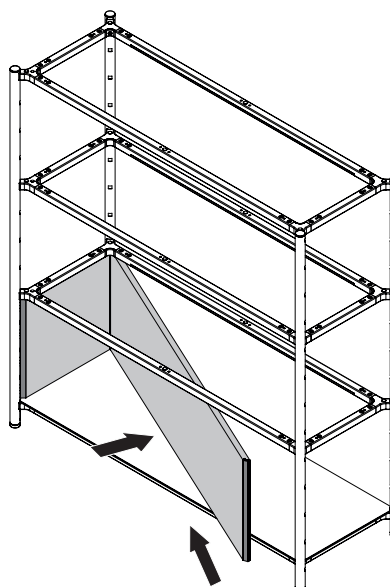

### 5.12 Large drawer assembly

**⚠ WARNING**

Risk of injury due to tipping of the furniture and falling products.

- > **Observe section Stability. Furniture with drawers must always be attached to the wall with a depth of 400 mm/15.748"!**
- > **Make sure that the fixtures and the base can support a pulling force of 0.1 kN per mounting point.**

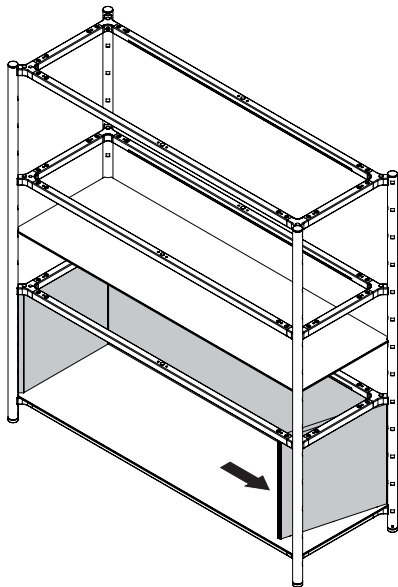

4. Two wooden covers can also be fitted back to back. In this way, for example, two adjacent niches can obtain different surfaces.

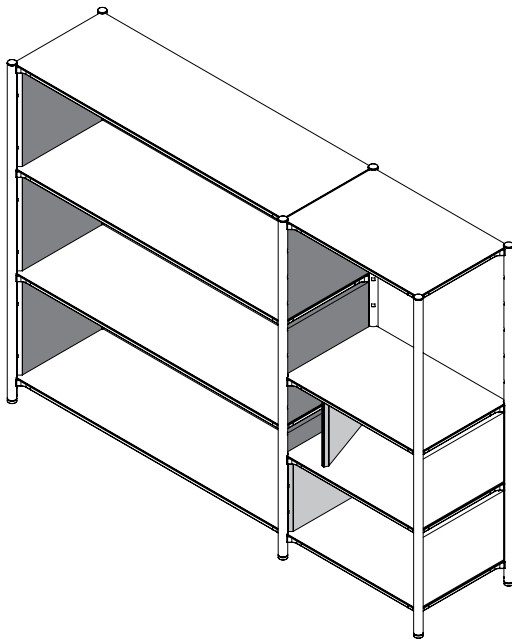

5. Insert the plastic clip into the wooden-panel-side groove first. Move this side against the upright and press the plastic clip into the slotting.

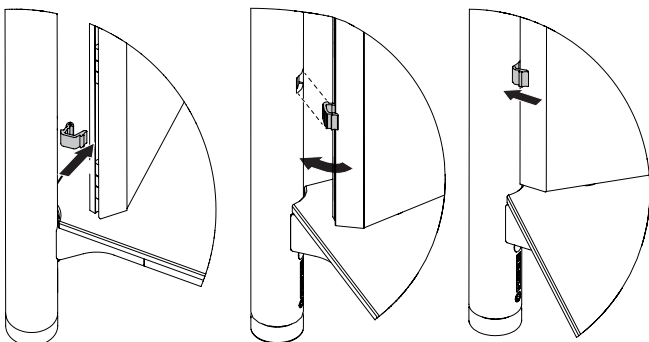

In the case of large drawers, no lower shelf is required.

1. When using plate covers, fit these first.

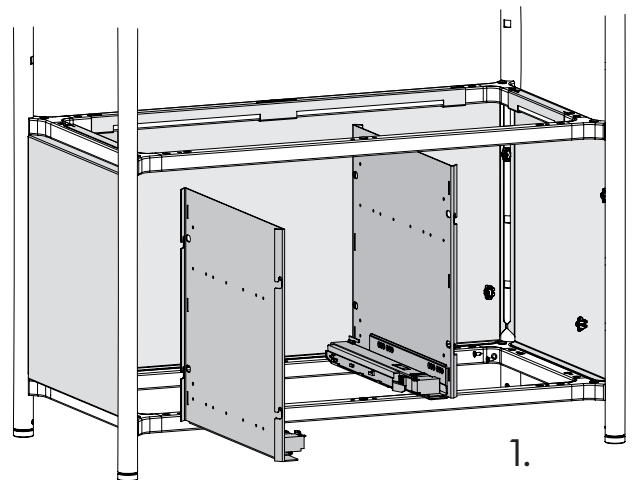

When using wooden covers, the pull-outs are mounted first (step 2-4).

2. For fitting the pull-outs, initially, the fastening clips must be mounted to the topmost and bottommost position in the upright.

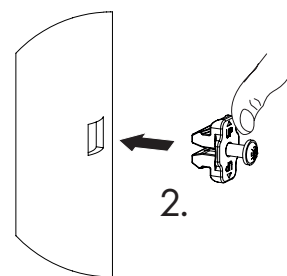

Undo the screw before removing the clip. Afterwards, pull the clip out of the hole using the lateral flaps.

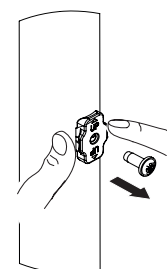

EN

3. Pulls the screw of the fastening clip until the pull-out plate can still be slightly hung over it.

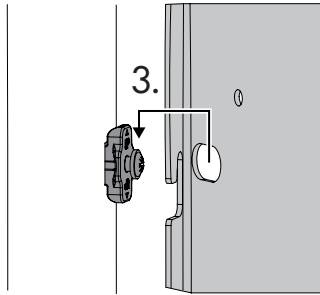

4. Then, firmly tighten the screw from the inside of the furniture and fix the pull-out plate in this way.

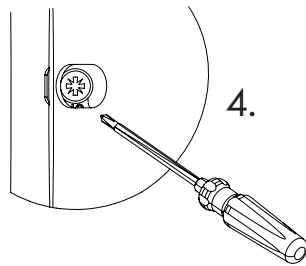

5. Hang in the plates for the back panel into the pull-out plates.
6. Screw the back panel on the hung-in plates. 4 screws per back panel.
7. The lateral covers must be screwed from the inside through the pull-out plates. 4 screws per side.

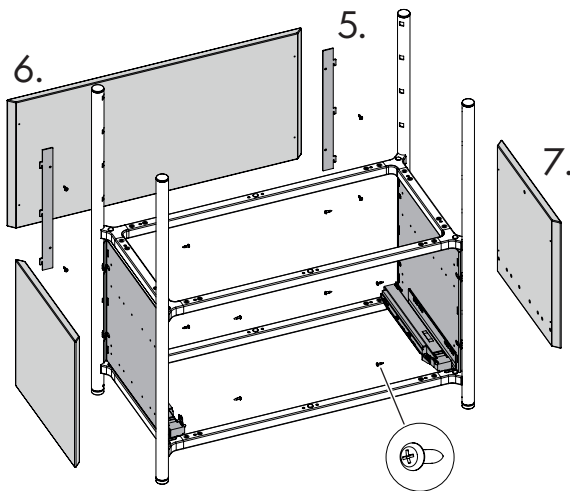

The cover of the large drawer can be secured using a bracket. The safeguard bracket is glued under the support insert.

1. Insert support insert.
2. Clean adhesive surface (dust- and grease-free).
3. Remove the of the double-sided adhesive tape film and glue the bracket onto the underside of the support insert.

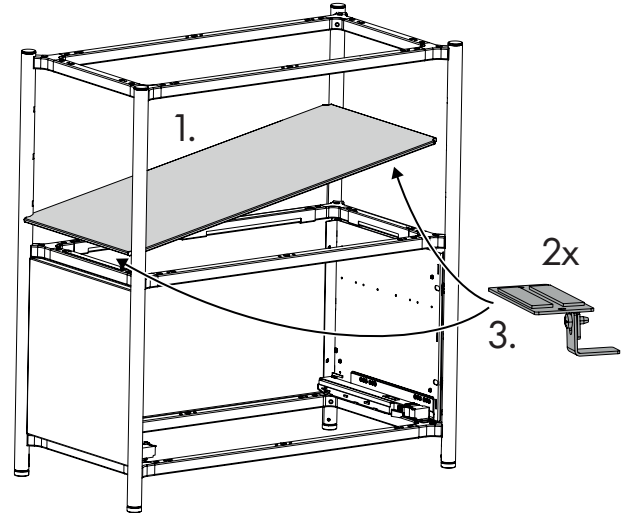

4. Adjust the position of the bracket and screw it in tightly.

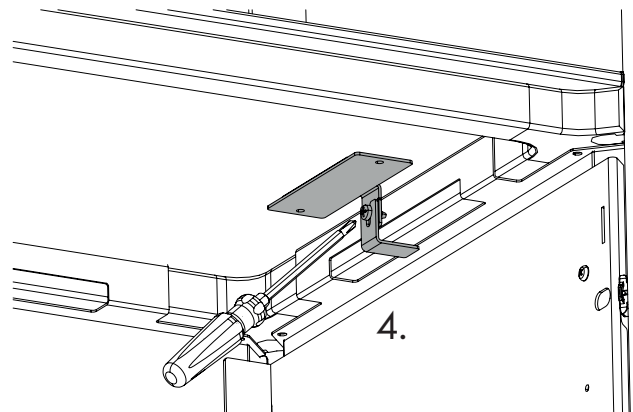

The drawer is inserted from the front onto the pull-outs and automatically engages. For details on assembly and adjustment of the drawers, please observe the assembly instructions of the large drawer manufacturer. Large drawer: Blum/ Legrabox/ Pure

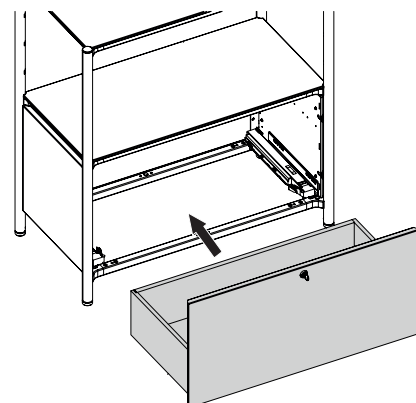



The large drawers are equipped with "push-to-open" technology and can only be opened and closed by pressing the centre of the drawer. A separate key (2x) is assigned to each lock.

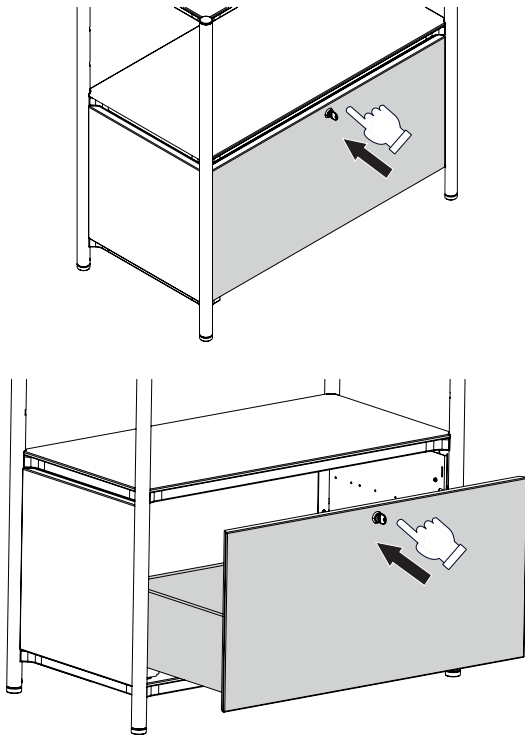

1. Place the platform insert with the top side down on the underlay (if required, packing material).
2. The platform support is glued in the centre of the support insert. In the case of wooden support inserts, it is possible to orientate oneself on the bore holes. The adhesive surface must be dust- and grease-free
3. Remove the adhesive tape covers on the platform support and glue them to the platform support insert. Press slightly.

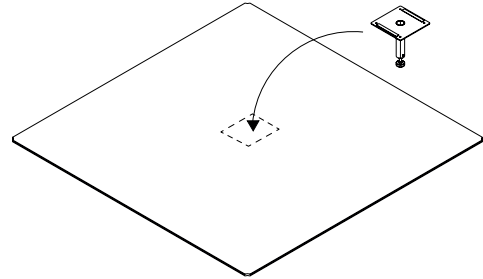

### 5.13 Platforms

**NOTE**

Platforms must only be constructed up to a height of 200 mm/7.874" and must only be used for presenting merchandise.

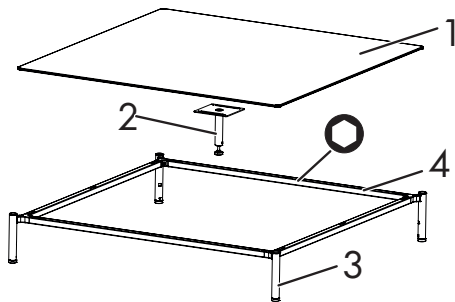

1	Platform support
2	Platform support
3	Platform uprights H 200/7.874"
4	Platform connection frame

Construct the platform according to section 5.5. Use 200 mm/7.874" uprights. Low platforms must be used with a connection frame.

For some platform support inserts, a platform support must be fastened to the underside of the support insert. The platform support must be contained within the scope of supply of the respective platform support insert.

### 5.14 Installing the hanging rails

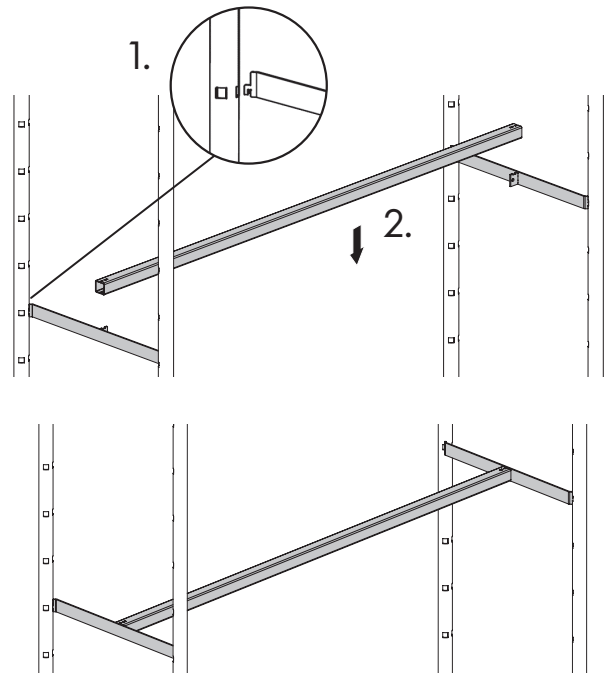
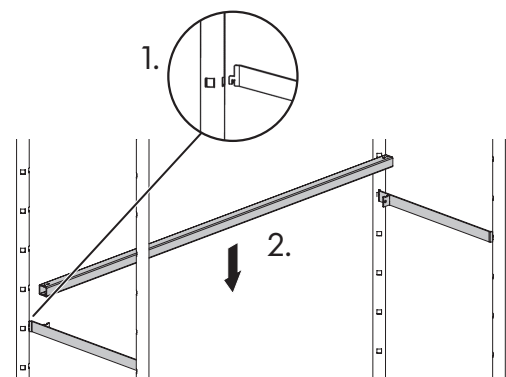

Fig. 19: Hanging rail for central space



EN

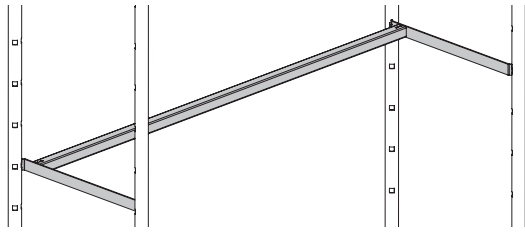

Fig. 20: Hanging rail for wall rack

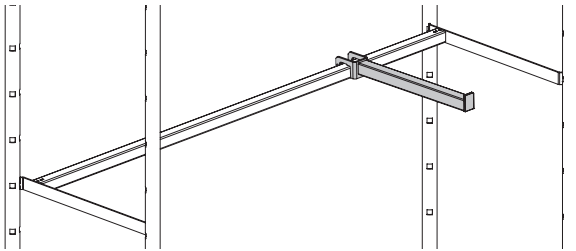

Fig. 21: Front arm for hanging rail

## 6 Dismantling / modification

### ⚠ WARNING

Risk of injury from goods or merchandise supports falling down. If the installation is not executed properly or if the substrate cannot accommodate the necessary loads, the system can fail.

> Make sure that the fixtures and the base can support a pulling force of 0.1 kN per mounting point.

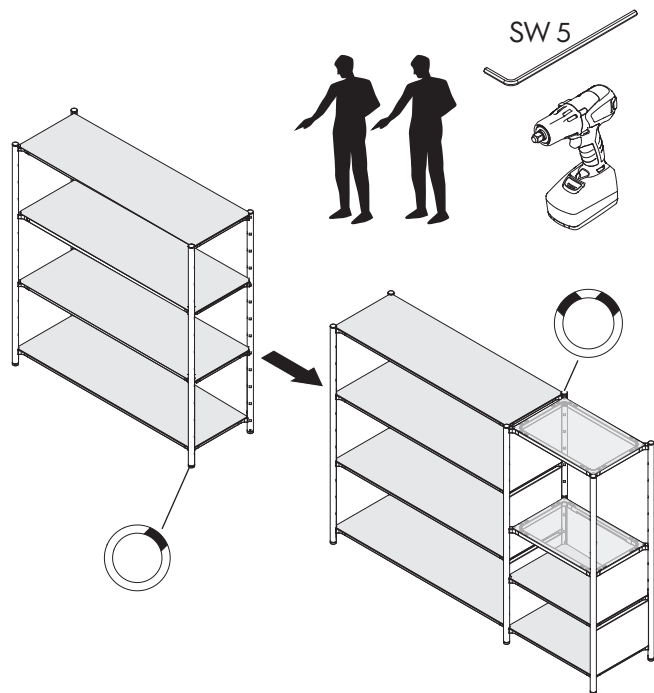

Dismantling is systematically performed from top to bottom. In the reverse sequence to the assembly described in **section 5**.

### NOTE

Prior to assembly / dismantling / modifying, the furniture must be disconnected from the mains.

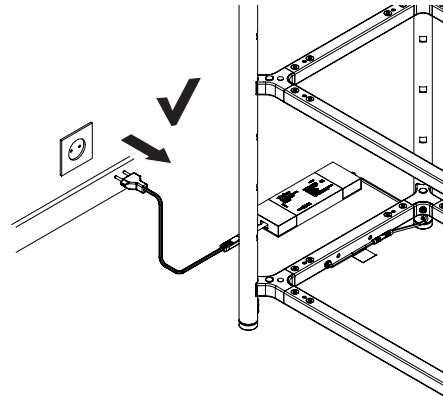

### Dismantling / modification procedure

1. Remove the pad on the top.
2. Push the lateral covers inwards and remove.
3. Repeat steps 1 and 2 with the lower niches.

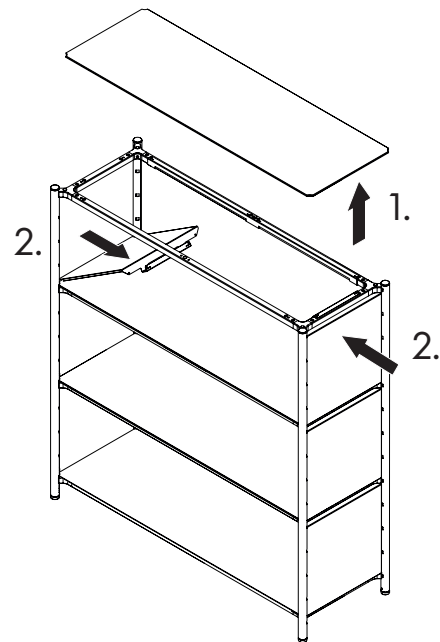

4. Loosen the screws on the top connection frame and remove the frames toward the top.
5. Loosen the two uprights in succession and replace them with new uprights.

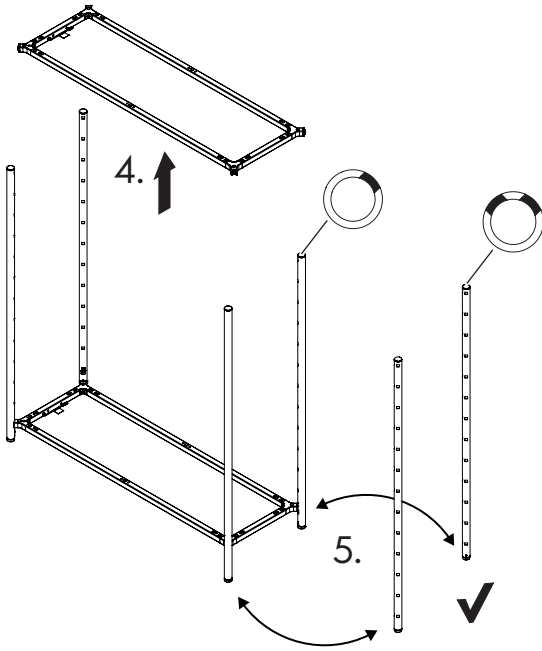

6. Fix the lower connection frame to the furniture.
7. Fasten the uprights on the bottom connection frame.
8. Fix the upper connection frame.

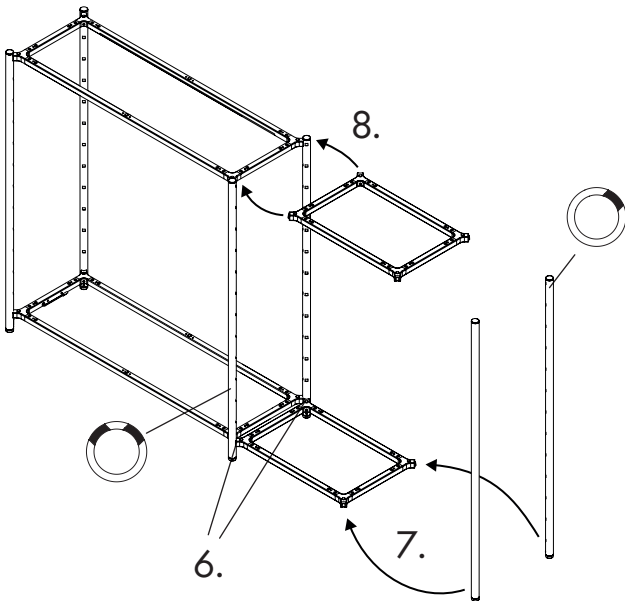

9. Fill the furniture with shelf frames, support inserts and lateral covers as is described in section 5.

## 7 Operation

### ⚠ WARNING

**Risk of injury from goods or merchandise supports falling down. The system can fail if the maximum permissible load of the merchandise support is exceeded.**

- > **Observe the maximum load values of the individual merchandise supports.**

### 7.1 Cleaning

During the course of time, dust and deposits from clothes hangers can settle on the merchandise supports. In order that the goods on display do not become soiled, the merchandise supports must be regularly cleaned.

Remove goods from the merchandise support.

1. Remove dirt on the merchandise support carefully with a soft, dry cloth.
2. Remove stubborn dirt with a mild cleaning agent.

## 8 Disposal

### NOTE

**Hazards to the environment can occur if product components are disposed of improperly.**

- > **Ensure product components are disposed of in a proper environmental manner or through waste management specialists.**
- > **Send components that can be recycled for recycling.**

- Send metal components for recycling or scrapping.
- Recycle plastic parts.
- Have an approved specialized disposal company dispose of electrical and electronic components.
- Dispose of other components according to their material characteristics.

## 9 Fault correction

### A shelf does not illuminate:

- Electrified shelf hangers?
- Electrified upright?
- Shelf electrification at the right point?

### No shelf illuminates:

- Check power connection: Power plug, cables
- Connection frame with feed cable with the correct side on the electrified upright?
- Electrified mount used?
- Connected load too high?

**Connected load too high:**

As a rule, the structure initially functions. The LEDs illuminate less intensely. The power supply unit heats up and the LEDs start blinking. The power adapter switches off after approx. 20 min.

- Disconnect power adapter and let it cool down. Reduce power (remove shelf frame)  
Connect power adapter again.

**In the case of a branched-out construction or one with several axes, the connection frame cannot be mounted:**

This can be due to the uprights being slightly contorted due to tolerances.

- Work in groups of two:
  1. One person holds the furniture.
  2. The other person slightly loosens the connection frames in the existing structure.
  3. Then, mount the frame that could not be mounted previously.
  4. Tighten all frames again.
- In the case of branched-out structures, it may be favourable to initially only fit the bottommost level of the structure until all uprights are connected. Then, tighten these firmly and afterwards, mount the second level.
- If the frame (\*) cannot be fit, slightly loosen the three adjacent frames.

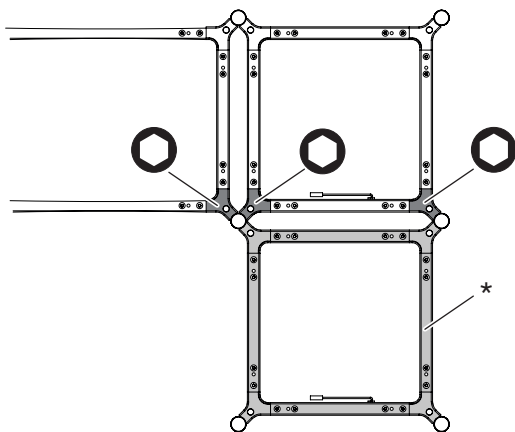

**visplay**

[www.visplay.com](http://www.visplay.com)

[visplay-usa@visplay.com](mailto:visplay-usa@visplay.com)